



UNIVERSITY OF CAMBRIDGE INTERNATIONAL EXAMINATIONS
International General Certificate of Secondary Education

CANDIDATE
NAME

CENTRE
NUMBER

| | | | | |
|--|--|--|--|--|
| | | | | |
|--|--|--|--|--|

CANDIDATE
NUMBER

| | | | |
|--|--|--|--|
| | | | |
|--|--|--|--|



ADDITIONAL MATHEMATICS

0606/11

Paper 1

May/June 2011

2 hours

Candidates answer on the Question Paper.

Additional Materials: Electronic calculator

READ THESE INSTRUCTIONS FIRST

Write your Centre number, candidate number and name on all the work you hand in.

Write in dark blue or black pen.

You may use a pencil for any diagrams or graphs.

Do not use staples, paper clips, highlighters, glue or correction fluid.

DO NOT WRITE IN ANY BARCODES.

Answer **all** the questions.

Give non-exact numerical answers correct to 3 significant figures, or 1 decimal place in the case of angles in degrees, unless a different level of accuracy is specified in the question.

The use of an electronic calculator is expected, where appropriate.

You are reminded of the need for clear presentation in your answers.

At the end of the examination, fasten all your work securely together.

The number of marks is given in brackets [] at the end of each question or part question.

The total number of marks for this paper is 80.

| For Examiner's Use | |
|--------------------|--|
| 1 | |
| 2 | |
| 3 | |
| 4 | |
| 5 | |
| 6 | |
| 7 | |
| 8 | |
| 9 | |
| 10 | |
| 11 | |
| 12 | |
| Total | |

This document consists of **16** printed pages.



Mathematical Formulae**1. ALGEBRA***Quadratic Equation*

For the equation $ax^2 + bx + c = 0$,

$$x = \frac{-b \pm \sqrt{b^2 - 4ac}}{2a} .$$

Binomial Theorem

$$(a + b)^n = a^n + \binom{n}{1} a^{n-1} b + \binom{n}{2} a^{n-2} b^2 + \dots + \binom{n}{r} a^{n-r} b^r + \dots + b^n,$$

where n is a positive integer and $\binom{n}{r} = \frac{n!}{(n-r)!r!}$.

2. TRIGONOMETRY*Identities*

$$\sin^2 A + \cos^2 A = 1$$

$$\sec^2 A = 1 + \tan^2 A$$

$$\operatorname{cosec}^2 A = 1 + \cot^2 A$$

Formulae for ΔABC

$$\frac{a}{\sin A} = \frac{b}{\sin B} = \frac{c}{\sin C}$$

$$a^2 = b^2 + c^2 - 2bc \cos A$$

$$\Delta = \frac{1}{2} bc \sin A$$

1 Show that $\frac{1}{1 - \cos\theta} + \frac{1}{1 + \cos\theta} = 2\operatorname{cosec}^2\theta$.

[3]

*For
Examiner's
Use*

2 Express $\lg a + 3\lg b - 3$ as a single logarithm.

[3]

- 3 (a) Shade the region corresponding to the set given below each Venn diagram.

For
Examiner's
Use

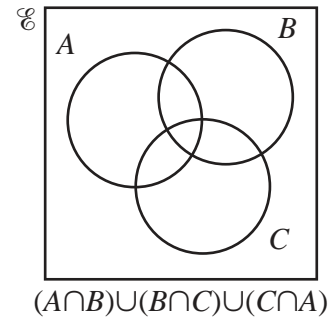
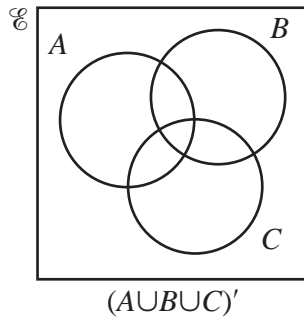
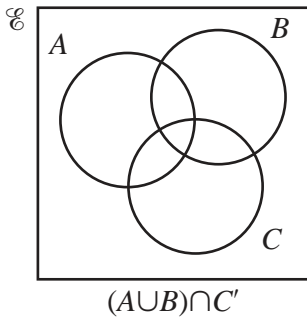

[3]

- (b) Given that $P = \{p : \tan p = 1 \text{ for } 0^\circ \leq p \leq 540^\circ\}$, find $n(P)$.

[1]

- 4 (a) Solve the equation $16^{3x-2} = 8^{2x}$.

[3]

(b) Given that $\frac{\sqrt{a^{\frac{4}{3}}b^{-\frac{2}{5}}}}{a^{-\frac{1}{3}}b^{\frac{3}{5}}} = a^p b^q$, find the value of p and of q . [2]

5 (i)

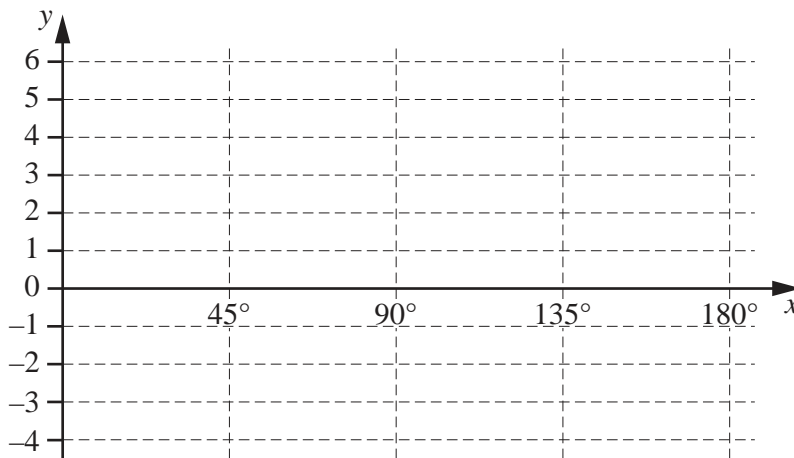

On the diagram above, sketch the curve $y = 1 + 3\sin 2x$ for $0^\circ \leq x \leq 180^\circ$. [3]

(ii)

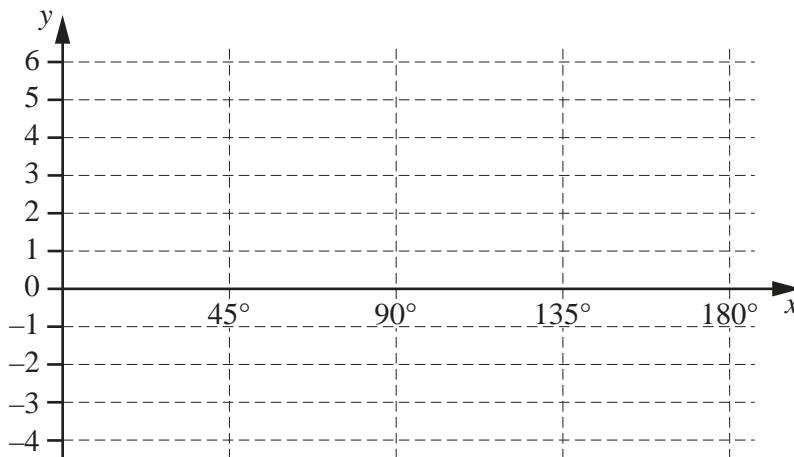

On the diagram above, sketch the curve $y = |1 + 3\sin 2x|$ for $0^\circ \leq x \leq 180^\circ$. [1]

(iii) Write down the number of solutions of the equation $|1 + 3\sin 2x| = 1$ for $0^\circ \leq x \leq 180^\circ$. [1]

- 6 The curves $y = x^2$ and $3y = -2x^2 + 20x - 20$ meet at the point A.

For
Examiner's
Use

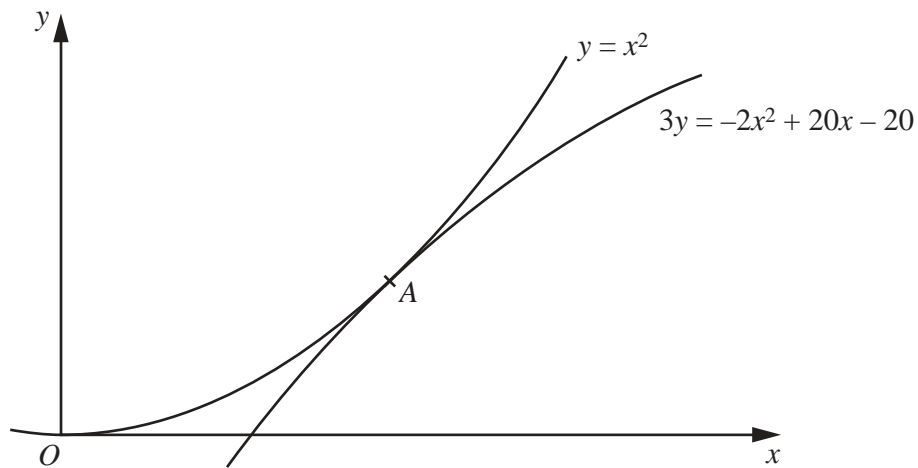

- (i) Show that the x -coordinate of A is 2. [1]
- (ii) Show that the gradients of the two curves are equal at A. [3]
- (iii) Find the equation of the tangent to the curves at A. [1]

- 7 The points A and B have coordinates $(-2, 15)$ and $(3, 5)$ respectively. The perpendicular to the line AB at the point A $(-2, 15)$ crosses the y -axis at the point C . Find the area of the triangle ABC .

[6]

*For
Examiner's
Use*

- 8 (a) The matrices **A**, **B** and **C** are given by $\mathbf{A} = \begin{pmatrix} 2 & 1 \\ 1 & 3 \\ 2 & 5 \end{pmatrix}$, $\mathbf{B} = \begin{pmatrix} 2 & 1 & 3 & 4 \\ 1 & 5 & 6 & 7 \end{pmatrix}$
and $\mathbf{C} = \begin{pmatrix} 9 \\ 10 \end{pmatrix}$. Write down, but do not evaluate, matrix products which may be calculated
from the matrices **A**, **B** and **C**. [2]

- (b) Given that $\mathbf{X} = \begin{pmatrix} 2 & 4 \\ 3 & 5 \end{pmatrix}$ and $\mathbf{Y} = \begin{pmatrix} 2x & 3y \\ x & 4y \end{pmatrix}$, find the value of x and of y such that

$$\mathbf{X}^{-1}\mathbf{Y} = \begin{pmatrix} -12x + 3y & 6 \\ -7x + 3y & 6 \end{pmatrix}. \quad [6]$$

9 A body moves in a straight line such that, t s after passing through a fixed point O , its displacement from O is s m. The velocity v ms^{-1} of the body is such that $v = 5\cos 4t$.

*For
Examiner's
Use*

(i) Write down the velocity of the body as it passes through O . [1]

(ii) Find the value of t when the acceleration of the body is first equal to 10ms^{-2} . [4]

(iii) Find the value of s when $t = 5$. [4]

10 (a) A curve is such that $\frac{dy}{dx} = ae^{1-x} - 3x^2$, where a is a constant. At the point $(1, 4)$, the gradient of the curve is 2.

*For
Examiner's
Use*

(i) Find the value of a . [1]

(ii) Find the equation of the curve. [5]

(b) (i) Find $\int (7x + 8)^{\frac{1}{3}} dx$.

[2]

*For
Examiner's
Use*

(ii) Hence evaluate $\int_0^8 (7x + 8)^{\frac{1}{3}} dx$.

[2]

11 (a) The function f is such that $f(x) = 2x^2 - 8x + 5$.

(i) Show that $f(x) = 2(x + a)^2 + b$, where a and b are to be found.

[2]

For
Examiner's
Use

(ii) Hence, or otherwise, write down a suitable domain for f so that f^{-1} exists.

[1]

(b) The functions g and h are defined respectively by

$$g(x) = x^2 + 4, \quad x \geq 0, \quad h(x) = 4x - 25, \quad x \geq 0.$$

(i) Write down the range of g and of h^{-1} .

[2]

- (ii) On the axes below, sketch the graphs of $y = g(x)$ and $y = g^{-1}(x)$, showing the coordinates of any points where the curves meet the coordinate axes. [3]

*For
Examiner's
Use*



- (iii) Find the value of x for which $gh(x) = 85$. [4]

12 Answer only **one** of the following two alternatives.

EITHER

The equation of a curve is $y = (x - 1)(x^2 - 6x + 2)$.

- (i) Find the x -coordinates of the stationary points on the curve and determine the nature of each of these stationary points. [6]
- (ii) Given that $z = y^2$ and that z is increasing at the constant rate of 10 units per second, find the rate of change of y when $x = 2$. [2]
- (iii) Hence find the rate of change of x when $x = 2$. [2]

OR

The diagram shows a cuboid with a rectangular base of sides x cm and $2x$ cm. The height of the cuboid is y cm and its volume is 72 cm^3 .

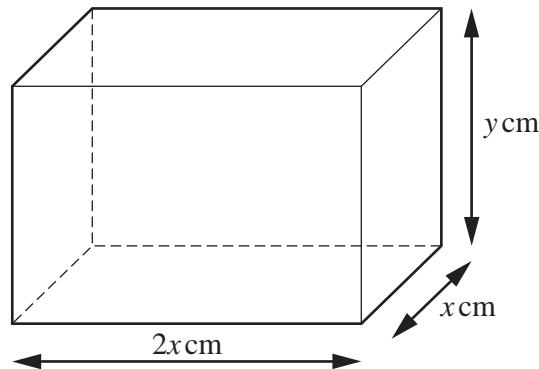

- (i) Show that the surface area $A \text{ cm}^2$ of the cuboid is given by
- $$A = 4x^2 + \frac{216}{x}. \quad [3]$$
- (ii) Given that x can vary, find the dimensions of the cuboid when A is a minimum. [4]
- (iii) Given that x increases from 2 to $2 + p$, where p is small, find, in terms of p , the corresponding approximate change in A , stating whether this change is an increase or a decrease. [3]

